

L-Series Soft Starters for Motors

User's Manual

Precautions

Attention



This sign indicates that there is a risk of personal injury or death, equipment damage or financial loss due to operational or environmental factors.

Attention



- Be sure to read these operating instructions in detail before installation.
 - The specifications of the motor must match this starter.
 - The exposed terminals must be wrapped with insulating tape after installation.
 - The soft starter or other associated equipment should be grounded.
 - The input power must be cut off during equipment maintenance.
 - The product must not be disassembled, modified or repaired by yourself.
-

Attention



• This soft starter contains electro-static discharge (ESD) components and assemblies that require static control measures during installation, testing, operation or maintenance. Failure to follow ESD control procedures can result in component damage. If you are not familiar with ESD precautions, please refer to the appropriate ESD manual.

Attention



• When this product is used with a reactive power compensation capacitor, it must be connected to the input side of the soft starter and not to the output side.

Attention



• When using delta internal wiring, dangerous high voltages acting on the terminals of the soft starter such as RST, UVW, etc. may cause shocks, burn or cause personal injury or death.

Attention



• Insulation testing of the input and output terminals of the soft starter with a megohmmeter is strictly forbidden and may result in damage to the internal semiconductor components of the product.

Attention



• Planning and installation, commissioning and subsequent maintenance of the system should only be carried out by professionals who are familiar with soft start and related mechanical systems, otherwise there is a risk of personal injury or equipment damage.

Attention



• Improper use and installation of soft starters can damage components and shorten the life of the product. For example, mismatching the soft starter to the motor capacity, incorrect or inappropriate supply voltage and high ambient temperatures can cause system malfunction.

Precautions	2
Contents	3
Product Information	4
Product Selection	5-8
External Dimensions	9
Installation	10-11
Connection	12-15
Operation	16-17
Table of Functional Parameters	18-24
Communication	26-27
Fault Diagnosis and Countermeasures	28-31
Warranty and After-sales Services	32

Product Information

Product Overview

The L-series soft starters are based on our latest product architecture platform (development code "Leopard"), which supports a wide range of bypass types. The "Leopard" architecture has been optimized and enhanced in terms of hardware and software compared to the previous SJR 2 series platform. Based on the latest 32-bit ARM architecture, the algorithm performance and functionality are further enhanced. The high-frequency optocoupler triggered SCR design replaces the traditional analog pulse drive, effectively improving the internal conduction efficiency of the SCR and reducing losses.

- Built-in power supply designed to allow the product to accommodate wide voltage fluctuations;
- Linear temperature detection — real-time monitoring of the product's operating temperature;
- Adjustable three-phase unbalance protection range and adjustable overload thresholds to cope with complex operating conditions;
- Built-in Chinese/English multilingual menu options, being freely switchable;
- Running time/running count function - provide convenience for maintenance;
- Adjustable underload protection for protection against dry burning in pump applications;
- Two programmable output relays/three programmable digital inputs/one analog output - various I/O interfaces;
- Integrated RS485 interface with support for Modbus protocol communication functions;
- Support for forced start mode (shutdown protection), which can cope with emergency start-up situations such as fire fighting;

Electric Parameters

Standard for compliance	GB/T 14048.6-2016/IEC 60947-4-2:2011
Three-phase power supply	Voltage (AC) 380V±15%
Frequency	50Hz/60Hz
Applicable motors	Three-phase squirrel-cage asynchronous motor
Starting frequency	Depending on the load, it is recommended not to exceed 20 times per hour
Protection level	IP (Agreeable, see the Shell Frame No. Marking for details)
Impact resistance	15gms
Seismic resistance	Below 3000m above sea level, with vibration force device below 0.5G
Ambient temperature	No reduction in capacity with the operating temperature between -40°C and +40°C (1.2% reduction in current for every 1°C increase between +40°C and +60°C)
Storage temperature	-25°C ~+70°C
Ambient humidity	95% free from condensation or water droplets
Maximum working height	No reduction in capacity up to an altitude of 1000m (above 1000m, 0.5% reduction in current for every 100m increase)
Maximum working angle	Maximum working angle relative to vertical mounting position No requirement

Operation functions

- current-limiting mode start
- Voltage ramp start
- Jump start
- Soft stop / free stop
- Two programmable relay outputs
- 4~20mA DC analog output
- RS485 communication control
- User password and running locks
- Three sets of fault history data logging

Protection functions

- Soft start for overheating protection
- Input phase loss protection
- Output phase loss protection
- Three-phase unbalanced protection
- Start overcurrent protection
- Operational overload protection
- Low voltage protection of power supply
- Overvoltage protection of power supply
- Underload protection (dry burning protection)

Protection Level

Depending on sizes, our soft starters may be available with an IP00 or IP2X protection levels and must be installed in the switchgear cabinet of IP54 (type 2) in consideration of the ambient conditions.

Make sure that no dust, liquids or conductive foreign matter get inside the soft starter. When the soft starter is working, it will produce waste heat (heat loss). Regular cleaning is helpful to extend the service life of the product. See product description for details.

Model Rules

□ **J R 3 - L E 0 7 5 T M 1 - 4 N**

①
②
③
④
⑤
⑥

①	Model	□JR3 series soft starters
②	Type	LE: External bypass LB: Built-in bypass LN: SCR Online without bypass LD: Bypass inside Delta LM: Mix bypass
③	Rated power	5R5~1000:5.5~1000kW (decimal points are indicated by "R")
④	Shell frame No.	Refer to the subsequent appendix for the corresponding dimension of shell frame number. Due to different product technology iteration or adaptation scenarios, the products with the same power may adapt to different shell frames, and the specific size shall be subject to the shell frame number on the order code.
⑤	Main voltage level	2: AC220V-240V 4: AC380V-440V 6: AC660V-690V E: AC1140V
⑥	Control voltage level	N: Internal control voltage (default) D2: External control voltage DC24V W2: External control voltage AC220V W4: External control voltage AC380V

Product Selection

Table for Selection of Specifications

Rated power of motor (kW) +10% to -15%		Soft starter rating	Soft starter model	Available appearance
230V	400V	ICL rating (A)		
4	7.5	15	LN-7R5	GS1 / GS3
5.5	11	21	LN-011	GS1 / GS3
7.5	15	29	LN-015	GS1 / GS3
9	18.5	35	LN-018	GS1 / GS3
11	22	42	LN-022	GS1 / GS3
15	30	57	LN-030	GS1 / GS3
18.5	37	69	LN-037	GS1 / GS3
22	45	81	LN-045	GS1 / GS3
30	55	100	LN-055	GS1 / GS3
37	75	131	LN-075	GS1 / TM1
45	90	162	LN-090	TM1
55	110	195	LN-110	TM1 / TL1
75	132	233	LN-132	TL1
90	160	285	LN-160	TL1
110	220	388	LN-220	TXL
132	250	437	LN-250	TXL
160	315	560	LN-315	TXL
-	355	605	LN-355	TXL
220	400	675	LN-400	TXL
250	500	855	LN-500	TXL / TXXL
355	630	1045	LN-630	TXXL
450	720	1200	LN-720	TXXL

Table for Selection of Specifications

Rated power of motor (kW) +10% to -15%		Soft starter rating	Soft starter model	Available appearance
230V	400V	ICL rating (A)		
4	7.5	15	LE-7R5	SS1 / GS2
5.5	11	21	LE-011	SS1 / GS2
7.5	15	29	LE-015	SS1 / GS2
9	18.5	35	LE-018	SS1 / GS2
11	22	42	LE-022	SS1 / GS2
15	30	57	LE-030	SS1 / GS2
18.5	37	69	LE-037	SS1 / GS2
22	45	81	LE-045	SS1 / GS2
30	55	100	LE-055	SS1 / GS2
37	75	131	LE-075	SS1 / GS2/ TM1
45	90	162	LE-090	TM1 / SM1
55	110	195	LE-110	TM1 / SM1
75	132	233	LE-132	TL1 / SM1
90	160	285	LE-160	TL1 / SM1
110	220	388	LE-220	TXL / SM1
132	250	437	LE-250	TXL / SM1 / SL1
160	315	560	LE-315	TXL / SL1
-	355	605	LE-355	TXL / SL1
220	400	675	LE-400	TXL / SL1
250	500	855	LE-500	TXL / TXXL / SL1
355	630	1045	LE-630	TXXL
450	720	1200	LE-720	TXXL

Product Selection

Table for Selection of Specifications

Rated power of motor (kW) +10% to -15%		Soft starter rating	Soft starter model	Available appearance
230V	400V	ICL rating (A)		
4	7.5	15	LB-7R5	SS1
5.5	11	21	LB-011	SS1
7.5	15	29	LB-015	SS1
9	18.5	35	LB-018	SS1
11	22	42	LB-022	SS1
15	30	57	LB-030	SS1
18.5	37	69	LB-037	SS1
22	45	81	LB-045	SS1
30	55	100	LB-055	SS1 / BSTU
37	75	131	LB-075	BSTU
45	90	162	LB-090	BSTU / SM2
55	110	195	LB-110	BSTU / SM2
75	132	233	LB-132	BSTW / SM2
90	160	285	LB-160	BSTW / SM2
110	200	380	LB-200	SM2 / SL2
132	250	437	LB-250	SL2
160	315	560	LB-315	SL2
185	355	605	LB-355	SL2

1: The product with the same power may be suitable for different housing sizes depending on the application conditions. Please confirm the model with the technical personnel before ordering.

2: The above values are the reference values based on the operating environment of the maximum ambient temperature of 40°C and an altitude of 1000m or less. The design rated capacity reduction due to high temperature and altitude should be considered when selecting the model.

3: The applicable current value of soft starter is recommended to be applied to Class 10 motor load. If it exceeds Class 10, the specifications shall be bigger properly during specifications selection.

Outer Dimensions

Outer Dimensions

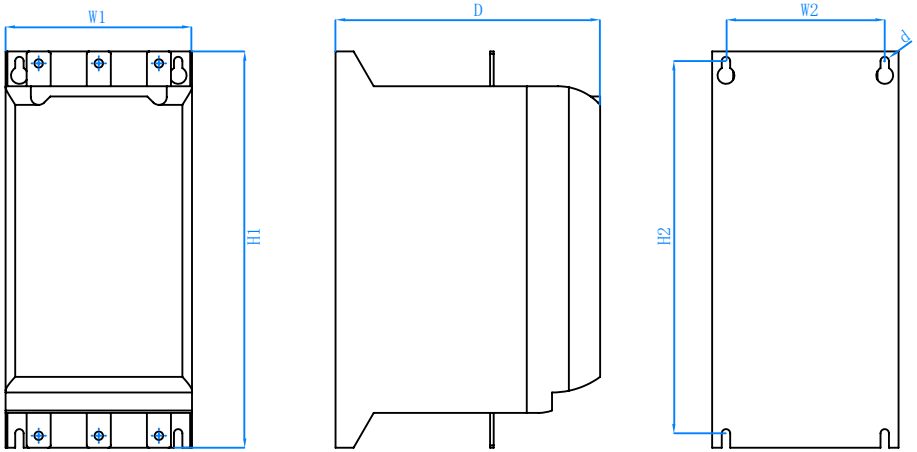

Suitable model	Shell frame No.	Outer dimensions			Mounting dimensions		
		H1	W1	D	H2	W2	Φ (Mounting hole)
LN	GS1	330	155	195	298	95	M6
LN/LE	TM1	370	210	260	343	150	M8
LN/LE	TL1	380	320	300	350	250	M8
LN/LE	TXL	560	395	317	523	300	M8
LN/LE	TXXL	810	610	391	770	400	M12
LE/LB	SS1	313	155	187	296	128	M6
LE	SM1	407	270	245	352	237	M8
LE	SL1	461	300	265	393	263	M8
LB	SM2	513	270	245	481	237	M8
LE	GS2	273	145	165	250	135	M6
LN	GS3	270	160	205	250	145	M6
LB	BSTU	340	200	240	320	160	M6
LN	TKL	560	395	317	523	300	M8
LB	BSTW	398	327	260	370	250	M8
LB	SL2	620	300	270	575	265	M8

Installation

Attention



Make sure that the number of input phases and the rated input voltage of the soft starter are the same as the number of phases and voltage of the AC power supply. AC power must not be connected to the output terminals (U, V, W); otherwise, damage may occur.

Attention



• When the load short circuit current exceeds the tolerance range of the maximum peak effective current of the SCR module, it will lead to damage to the SCR. Users should consider adding a special fast fuse for semiconductor protection to the main circuit of the soft starter to aid short circuit protection.

Receipt of goods

It is the user's responsibility to check the equipment carefully before signing for the goods delivered by the shipping company and to check the goods received against the order sheet. If any damage is found to the goods, the user has the right to refuse to sign for the goods until the shipper has marked the damage on the freight bill. If any internal hidden damage is found during unpacking, it is also the user's responsibility to inform the shipper. The shipping packaging of goods must be left intact and that the shipper should be asked to visually inspect the goods.

Unpacking

After unpacking, check each item against the packing list in accordance with the order sheet.

Inspection

Prior to installation, the soft starter should be placed in the container in which it was shipped.

Storage

If the equipment is not to be used immediately but is to be stored for a period of time, it should be stored in accordance with the following requirements to ensure effective operation.

- Storage in a clean and dry environment.
- The ambient temperature must be between -20°C and $+75^{\circ}\text{C}$.
- The relative humidity must be in the range of 0% to 95% without condensation.
- The equipment must not be exposed in an environment with corrosive air.
- The equipment must not be stored on construction sites.

Note: In addition to the soft starter, a copy of the operating instructions and a product quality conformity certificate are included.

The body of the soft starter must be held when moving and the circuit board control box cannot be lifted; otherwise, damage or personal injury may incur.

Installation Requirements

- ① Soft starters should be mounted vertically, do not mount upside down, obliquely or horizontally, please use screws to mount it on a solid structure.
- ② The soft starter generates heat during operation and a certain space is kept at design to ensure passage for flowing air. Heat is generated and dissipated upwards, so do not install it under non-heat-resistant equipment.

Installation Requirements

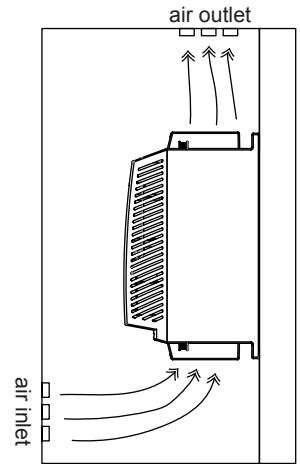
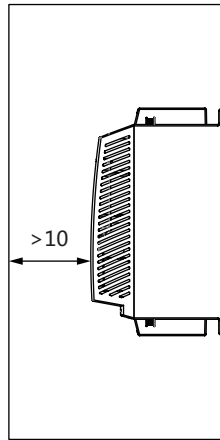
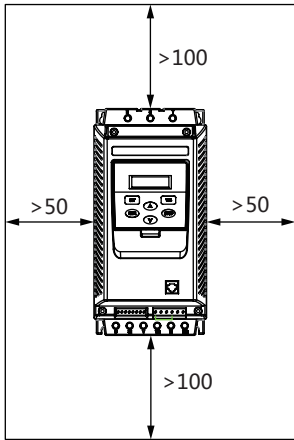

Soft starter (230~400V) should be connected to the delta winding of the motor, in series connection with each winding

Soft starters can be connected in series to the delta winding of the motor. They are driven by $1/\sqrt{3}$ 3-wire current so that under-rated starters can be used.

Example: one unit 400V - 110kW motor with a line current of 195A (rated current of delta connection). The current in each winding is equal to $195/1.7$, i.e. 114A.

Choose the rated value with the maximum allowable rated current slightly higher than this current, i.e. 140A as the rating (SJR3-075 for standard applications).

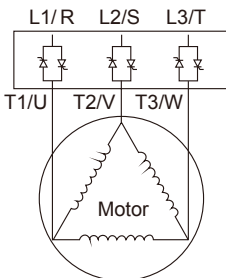

Directly-connected delta external connection

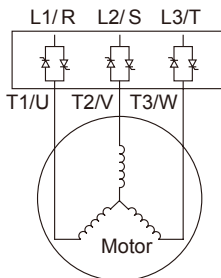

Directly-connected star external connection

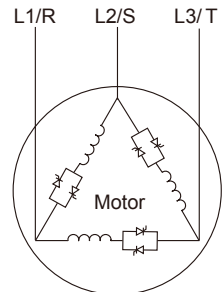

Delta soft start internal connection

For L-series products, only LD specification supports delta internal connection of motor, and other specifications do not support internal connection.

Connection

Basic circuit connection diagram

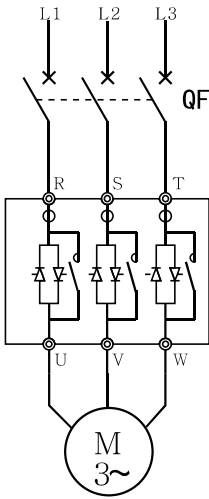

LB built-in bypass type

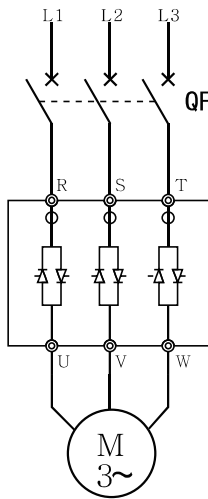

LN module online type

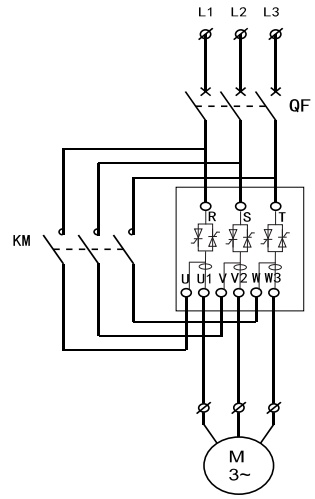

LE external bypass type

Functions of Main Circuit and Grounding Terminals

Marking of terminal	Name of terminal	Notes
L1/R, L2/S, L3/T	Main circuit power input	Connect to three-phase power supply
T1/U, T2/V, T3/W	Output connection of soft start	LD, LB and LN series are connected to three-phase motor, LE series is used to connect the output terminal of bypass contactor
U1, V2, W3	Output terminal of soft start	External bypass is used to connect the output terminal of bypass contactor in application

Input Terminal of Main Circuit Power Supply (R/S/T)

- ① The input terminals R, S and T of main circuit power supply are connected to the three-phase AC power supply through circuit breaker or circuit breaker with leakage protection for line protection, without regard to the phase sequence of the connection.
- ② Do not use the main circuit power ON/OFF method to control the run and stop of the soft starter. Wait until the soft starter is energized and then choose to use the control terminals on the soft starter or the run and stop keys on the keypad panel to control the run and stop of the soft starter.
- ③ Do not connect to single-phase power supply.

Output Terminal of Soft Start (U/V/W and U1/V2/W3)

- ① The output terminals of soft starter should be connected to the three-phase motor in the correct phase sequence. If the rotation direction of the motor is not correct, the connection of any two phases of U, V and W can be swapped.
- ② Capacitor and surge absorber cannot be connected on the output side of soft starter.
- ③ When the wire between the soft starter and the motor is very long, the distributed capacitance between the wires will generate a large high-frequency current, which can cause the overcurrent tripping of the soft start, the increase of the leakage current, the poor accuracy of the current display, etc. It is therefore recommended that the wire of motor connections does not exceed 50m.

Attention



Solid state power switching elements can overheat due to motor failure. To avoid personal injury or equipment damage, here are several recommendations:

Please use isolating contactor or shunt release circuit breaker on the circuit of soft starter. The device shall be capable of blocking the additional locked rotor current of the motor. Please connect this isolating device to the auxiliary contact on the soft starter, which shall be programmed to apply to the normal position.

Connection of Control Terminals

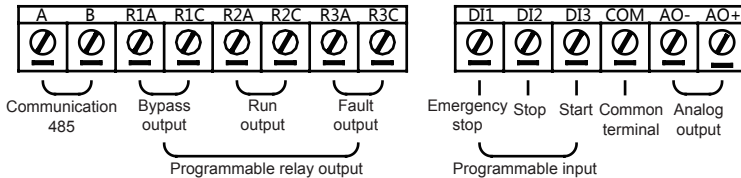

(The terminal function marked in the above figure is only the default setting value, and the actual function can be changed through parameter setting)

Description of Control Circuit Terminal

Marking of terminal		Description of function	
A	A	RS485-A	RS485 communication interface
B	B	RS485-B	
01	R1A	K1, programmable relay output (default bypass output)	
02	R1C		
03	R2A	K2, programmable relay output (default run output)	
04	R2C		
05	R3A	K3, programmable relay output (default fault output)	
06	R3C		
07	DI1	DI1, programmable input (default emergency stop input)	
08	DI2	DI2, programmable input (default shutdown input)	
09	DI3	DI3, programmable input (default start input)	
10	COM	Programmable input common terminal	
11	AO-	Analog Output -	DC 4~20mA (0~20mA can be preset, function code of F26)
12	AO+	Analog Output +	

01, 02: When selecting LN series, connecting bypass may cause failure of current online detection.

03, 04: The programmable relay output is a normally open point which will close when the output is effective.

Connection

05, 06: The programmable fault relay output, closes in the event of a soft starter fault or power failure and opens when power is on.

07, 10: The motor stops immediately when it is disconnected (or connect the normally-closed contact of other protectors in series).

08, 10: The motor executes soft stop with deceleration when it is disconnected (or self-stop, refer to the setting value of F02).

09, 10: The motor starts to operate when it is closed.

11, 12: It is a 4~20mA DC analog output used for real-time monitoring of motor current. When the motor is full of 20mA, it indicates that the motor current is 100% of the nominal rated current of the soft starter (adjustable by code F27). It can be observed by an external 4~20mA DC meter. The output load resistance is of 300 Ω .

① When using external terminals to control the run and stop function of the soft starter, set code F00 to be valid for the terminals.

② If remote control is required, it is recommended to use the (2-wire) control method.

③ The input terminal of contact signal and common terminal are normally closed/open (ON/OFF). The soft starter, motor and wiring will cause interference. Therefore, the wiring should be shorter (less than 20m). Please use shielded wire as the cable.

④ Make sure that the wiring of the control terminals is as far away from the wiring of the main circuit as possible; otherwise, there may be incorrect operation due to interference.

⑤ If the control mode is communication, the emergency stop terminal must be short-circuited.

⑥ Notice the capacity limit (AC250V/3A) of 03~06 relay contact, for example, when connecting with high-rated contactor, pay attention to the working limit of relay contact.

⑦ The functions and normally closed and normally open logic of the control terminal are different according to different function settings, which shall be adjusted according to the actual situation.

Preparation for Inspection before Operation

The following items shall be checked and prepared before operation

- (1) Check whether the wiring is correct, especially the output terminal cannot be connected to the power supply.
- (2) Confirm that there is no short circuit or short circuit to ground between terminals or exposed live parts.
- (3) The keyboard panel displays the [Ready] state after the power is connected.

Operation Method

Select the appropriate operation method according to the requirements. It's set as terminal control before leaving factory (function code F00)

- Display the [Ready] state when powering on, and press the run key to start the motor (only when F00 is 0).
- Input the setting item F07 according to the rated current value on the motor nameplate.
- Check whether the rotation direction of the motor is correct after starting. If not, press the stop key to stop the machine or cut off the power supply if necessary, and then swap two wires (UVW) of the motor at will.

- If the starting state of the motor is not ideal, refer to the starting mode and application column of the soft starter to select the appropriate setting items.
- When the torque fails to reach the proper effect, the starting voltage code F03 (in voltage mode) or the current-limiting value code F04 (in current mode) can be changed to increase the starting torque of the motor.
- Do not open the upper cover after energizing the soft starter to avoid electric shock.
- If abnormalities such as abnormal sound, smoke or odour are detected during the power-on test run, cut off the power quickly and find out the cause.
- If a fault occurs after power-on or during startup, find out the cause according to the page table corresponding to the displayed fault code.
- Press the stop key or the external control stop button to reset the fault state.

Standard Application Wiring Diagram

Three-wire Control

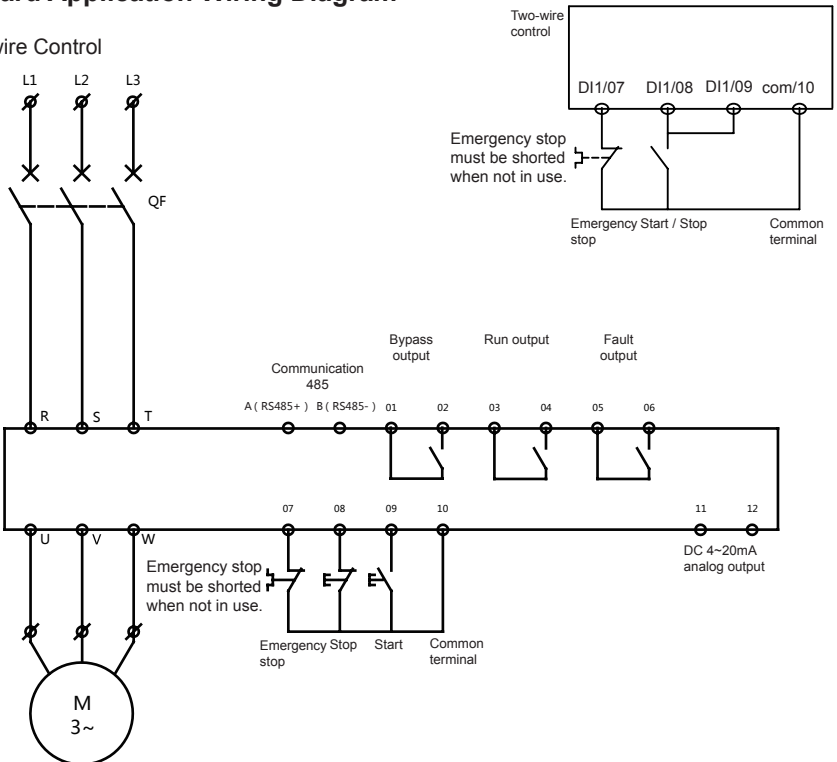

Operation

Function of Operation Keys

Name of Keys	Main Functions
Run key	When [Ready State] is displayed, press this key to start, while [Start State] is displayed.
Stop key	When in normal operation [Run State] is displayed, press this key to stop. When in soft stop [Soft Stop State] is displayed, this key has the function of resetting the fault state.
Set key	Press this key to enter the menu setting, and press this key again to exit the menu interface.
Confirmation key	In the menu setting interface, press this key to modify the parameters. The displayed arrow points to the code setting line. After modifying the parameters, press this key to save, which means the data has been saved.
Up and down keys $\Delta \nabla$	Enter the menu setting and enter the code setting line. Press to modify the parameters. During operation, this key can observe the grid voltage, radiator temperature and historical faults during operation.

Appearance of Keyboard Panel

The keyboard panel has a wide range of operating functions, such as the keyboard panel run and stop function, data confirmation and change, and various status confirmation functions.

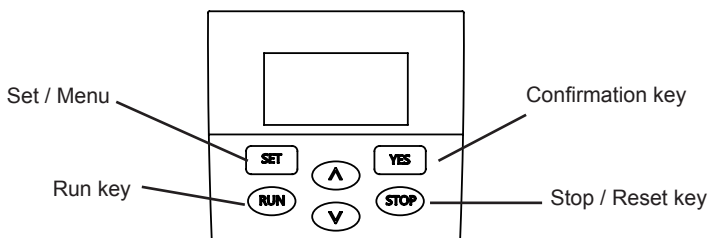

Key Style One

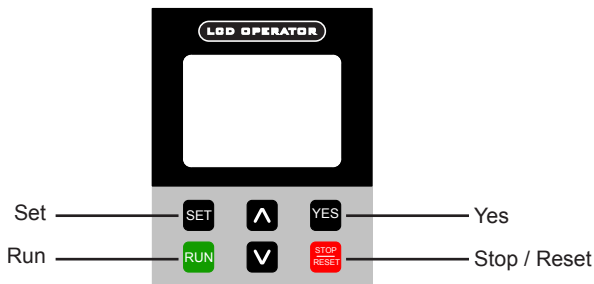

Key Style Two

Operating Steps

Modify Setting Parameters

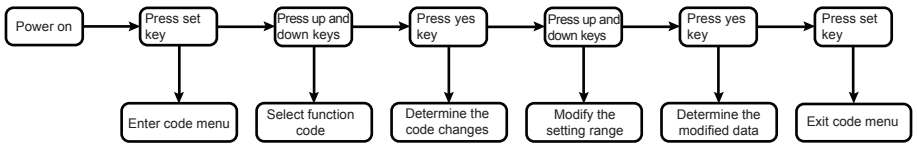

Take modification (start mode is current-limiting mode, i.e. code F01 is set as 01) as an example.

No.	Operation	Display	Notes
1	Power on	[Ready State]	[Ready State]
2	Press set key	» Run command channel F00 01	Enter the menu setting function code option state
3	Press down key	» Start mode F01 00	Enter code F01 (start mode) Function option state
4	Press yes key	Start mode F01 » 00	Setting range can be modified
5	Press down key	Start mode F01 » 01	Indicates modification to current-limiting mode control
6	Press yes key	» Start mode F01 01	Modified data has been saved
7	Press set key	[Ready State]	Exit the menu setting function code option state

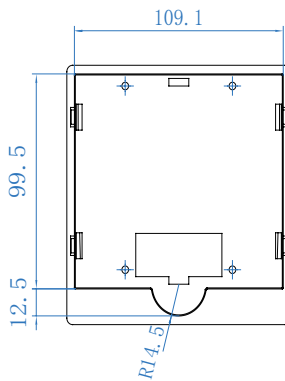

Dimensions of external keyboard compartment (optional)

Table of Functional Parameters

Code setting function

Setting Code Instructions				
Code	Name	Setting range	Factory settings	Notes
F00	Run command channel	0~3	1	0: Operation panel command channel 1: Terminal command channel 2: Communication command channel 3: Operation panel+ external control terminal + communication command are effective at the same time
Reading data for communication is not affected by command channel settings.				
	Start mode	0~2	0	0: Voltage ramp 1: current-limiting mode 2: Heavy load
F01				<p>Output waveform in voltage ramp mode is shown. U_1 is the starting voltage value at startup. When the motor is started, the output voltage of the soft starter rises rapidly to U_1 within the range that the motor current does not exceed 400% of the rated value (according to the setting of current-limiting multiple F04), and then the output voltage gradually rises according to the set startup parameters. The motor is accelerated steadily with the rise of voltage. When the voltage reaches the rated voltage U_e, the motor reaches the rated speed and switches to the operating state. The starting process is completed. Starting time: t is the control parameter obtained under standard test conditions according to standard load. With this parameter as the benchmark, the starting process is completed by controlling the output voltage to make the motor accelerate stably. It is not to mechanically control the time t regardless of whether the motor accelerates stably. Therefore, when the load is light, the starting time is usually less than the set starting time. It is normal as long as it can be started smoothly. Generally speaking, voltage ramp starting mode is applicable to the occasion with less strict requirements on starting current and higher requirements on starting stability.</p>

Table of Functional Parameters

Setting Code Instructions

Code	Name	Setting range	Factory settings	Notes
F01				 <p>Current variation waveform in current-limiting mode is shown. I1 is the set starting current-limiting value. When the motor starts, the output voltage increases rapidly until the motor current reaches the set current-limiting value I1, and the motor current is maintained not greater than this value. Then, with the gradual increase of the output voltage, the motor gradually accelerates. When the motor reaches the rated speed, it is switched to the operating state, and the output current rapidly drops to the rated motor current Ie or below. The starting process is completed. When the motor load is light or the set current-limiting value is large, it is normal that the maximum current during starting may not reach the set current-limiting value. The current-limiting starting mode is generally used for occasions with strict requirements on starting current.</p>
F02	Stop mode	0, 1	0	0: Soft stop 1: Free stop
F03	Start voltage	30~60%	40%	Voltage ramp mode is valid; in current mode, starting voltage is 40%
F04	Current limiting multiple	50~500%	400%	The allowable upper limit current during startup (percentage of F07 motor rated current), when the current limit value is reached, the soft current automatically limits the operating current; When the current limiting multiple exceeds 400%, the set motor current shall be met $(F07) \times 125\% \leq \text{soft start rated current}$, if not, soft starter of larger specification shall be selected.
F05	Start time	1~30s	10s	Voltage ramp start time (current limiting mode is invalid)
F06	Stop time	0~30s	10s	Free stop when set to 0 This value shall be set to 0 when the circuit design requires the use of a soft starter for one-to-multiple switching start (cascading).
F07	Rated current of motor	0~rated value	-	Rated current of motor Please refer to the motor nameplate to set this value. The maximum setting range of different specifications is less than the rated current of the soft starter; Reference range: $[\text{rated current of soft start} \times 0.4] < [\text{set current (F07)}] < [\text{rated current of soft start}]$.

Table of Functional Parameters

Setting Code Instructions				
Code	Name	Setting range	Factory settings	Notes
F08	Voltage jump	50~100%	50%	
F09	Jump time	0~30s	1s	
F10	Overvoltage alarm delay	0~600s	30s	The default overvoltage threshold is >500V (380V specification), please contact our company for adjustment.
F11	Undervoltage alarm delay	0~600s	60s	The default undervoltage threshold is <250V (380V specification), please contact our company for adjustment.
F12	Load unbalance degree	0~50%	20%	Allowable deviation range of output three-phase current
	This parameter should not be set too high, and improper setting will lead to protection failure.			
F13	Time of unbalance	0~600s	20s	Delay time of protection action after reaching the set value of F12
	This parameter should not be set too high, and improper setting will lead to protection failure.			
F14	Allowable underload	0, 1	1	0: Underload protection is valid, 1: Underload is allowed and protection is invalid
F15	Time of allowable underload	0~600s	10s	
F16	Multiple of allowable underload	0~100%	20%	
F17	Time of operation overcurrent	0~600s	60s	The continuous time that the actual operating current exceeds the overload threshold
F18	Interval time of continuous starting	0~300s	0s	Interval between two consecutive starts. Continuous starting may cause system overheating.
	This parameter can be used to prevent heat build-up of the module due to frequent starts or malfunction of mechanical equipment.			
F19	Operational overload threshold	50~300%	150%	The judgment value of motor overload state, the judgment threshold is the percentage of rated motor current (F07) and this parameter
	<p>The threshold is invalid during startup; This parameter should not be set too high, and improper setting will lead to protection failure. When the current reaches and exceeds the set value and meets the overcurrent protection delay time of F17 for a continuous period, overload protection is carried out, the machine is stopped and fault code Err06 is prompted; This parameter can be used in conjunction with the overload protection level setting combination of function code F58.</p>			

Table of Functional Parameters

Setting Code Instructions				
Code	Name	Setting range	Factory settings	Notes
F20	Fan operating mode	0, 1	0	0: The fan operates continuously during operation, 1: Run after the temperature reaches warning value (40 ° C / 104 ° F)
	Only applicable to product models equipped with forced air cooling; This function is used to set the operating state of the fan in the standby state, and the fan is forced to operate after startup;			
F21	Language selection	0, 1	0	0: Chinese 1: English
	The language setting is not restored after setting F39 to restore the factory value			
F22	Module Bypass Selection	0~2	0	0: Online 1: SCR module works in bypass state 2: SCR module does not work in bypass state
	When the circuit design requires the use of a soft starter for one-to-multiple switching start, this value shall be set to 2;			
F23	DI1 function	0~4	0	0: Emergency stop, 1: Stop, 2: Start, 3: Reset, 4: Input of external fault signal
F24	DI2 function		1	
F25	DI3 function		2	
F26	AO output mode	0, 1	0	0: 4~20mA , 1: 0~20mA
F27	AO zero offset correction coefficient	0~200%	100%	Zero offset ratio of percentage of rated current of soft starter corresponding to analog output value
F28	AO gain calibration coefficient	1~500%	100%	The upper limit of analog output value is the percentage of rated current of soft starter
	F27 and F28 function codes are used to correct the zero drift of analog output and the deviation of output amplitude. If the zero drift is represented by b, the gain is represented by k, the actual output is represented by Y, the standard output is represented by X, and X=the rated current of the soft starter, then the actual output is: Y=kX+b; Example: motor rated current is set to 100A, the ideal upper output limit of Y is 500% of rated value, and the output mode is 0~20mA; Due to the effective operating range limit of the internal sensor, the analog output range			
F29	K1 relay function (R1A-R1C)	1	1	0: Fault state (normally open) 1: Bypass state (normally open) 2: Operating state (normally open) 3: Soft start state (normally open) 4: Soft stop state (normally open)
F30	K2 relay function (R2A-R2C)	0~9	2	5: Fault state (normally closed) 6: Bypass operation (normally closed) 7: Operating state (normally closed) 8: Soft start state (normally closed) 9: Soft stop state (normally closed)
F31	K3 relay function (R3A-R3C)	0~9	0	

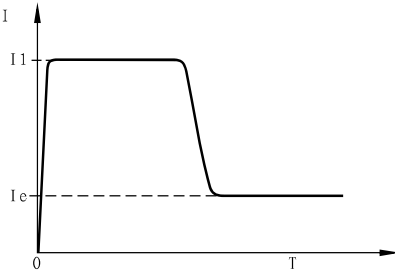
Table of Functional Parameters

Setting Code Instructions								
Code	Name	Setting range	Factory settings	Notes				
F32	Bypass output delay	0~600s	0s	K1 terminal after operation, i.e. maximum load current of 10A for delay time of bypass output relay action				
	Part of large inertia load cannot reach the rated speed after soft start full voltage output, and the operating current is still at a higher level. This parameter is used for delay closing of thyristor, which can avoid bypass contactor closing at a higher current level.							
F33	K2 relay output delay	0~600s	0s	Output delay time of multi-function relay Maximum load current: 5A				
F34	K3 relay output delay	0~600s	0s					
F35	Programmable operation time	0~32000s	0s					
F36	Communication address	0~128	1	Broadcasting when set to 0				
F37	Baud rate	0~3	2	0: 2400bps, 1: 4800bps, 2: 9600bps, 3: 19200bps				
F38	Data format	0~2	0	0: N.8.1 1: 0.8.1 2: E.8.1				
F39	Reset to factory defaults	0~1	0	1: Reset to factory defaults				
	F07; F21; F26; F27; F28; F32; F37; F41; Parameters such as fault record and cumulative operation record are unrecoverable							
	Disable protection	-	0	This parameter is used to select the closing protection function. If the corresponding protection function needs to be closed, set the corresponding position in the following table to 1, and convert the binary value to decimal value and set it to F40. This parameter will cause protection failure. Please apply this parameter carefully.				
F40	Disable protection function (0: protection active/1: protection disabled)							
	Bit7	Bit6	Bit5	Bit4	Bit3	Bit2	Bit1	Bit0
	Inverse time overload (18)	Operation overload (6)	Three-phase unbalance (10)	Underload (9)	Start Timeout (3)	Overvoltage (7)	Undervoltage (8)	Overheating (4)
0	0	0	0	0	0	0	0	
Example: If the overheating protection and overvoltage protection are to be switched off, the binary code "0000101" should be converted to the corresponding decimal value of "5".								
Important note: Disabling protection function may cause damage to the equipment. Please use this function as appropriate. This manual has fulfilled the obligation to inform you. We assume no responsibility for the loss caused by the disable protection. This function can be used in situations where emergency start is required, such as fire fighting.								

Table of Functional Parameters

Setting Code Instructions

Code	Name	Setting range	Factory settings	Notes
F41	Bypass delay time	0~10S	1	Delay switch-off time of thyristor after soft start stop signal is given
	When the circuit design requires the use of a soft starter for one-to-multiple switching start, this value shall be set to 0;			

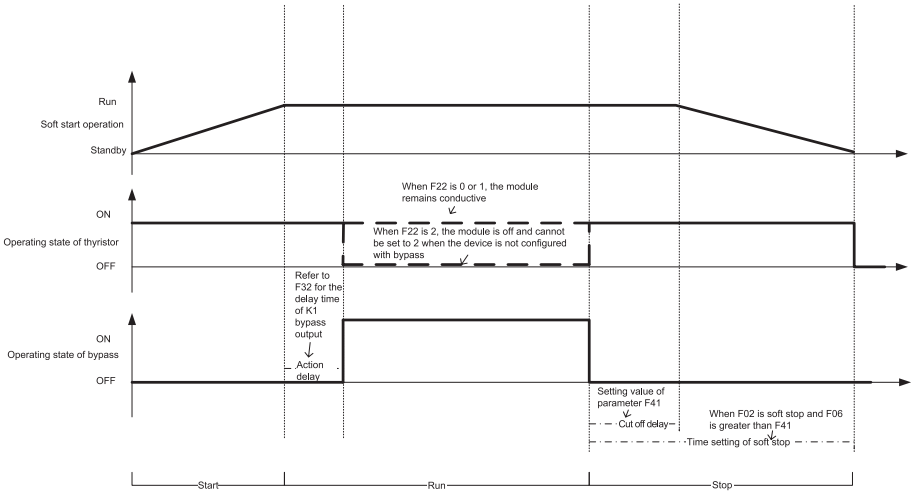

F42	Fault record 1 (last) Type of fault	Err01-18	-	(Last) Display of fault and the voltage, current and temperature at fault. If the last fault is the same type as the previous fault, only the last fault record is displayed.
F43	Fault record 1 Voltage at fault	-V	-	
F44	Fault record 1 Current at fault	-A	-	
F45	Fault record 1 Temperature at fault	-°C	-	
F46	Fault record 2 Type of fault	Err01-18	-	Display fault and the voltage, current and temperature at fault
F47	Fault record 2 Voltage at fault	-V	-	
F48	Fault record 2 Current at fault	-A	-	
F49	Fault record 2 Temperature at fault	-°C	-	

Table of Functional Parameters

Setting Code Instructions				
Code	Name	Setting range	Factory settings	Notes
F50	Fault record 3 Type of fault	Err01-18	-	Display fault and the voltage, current and temperature at fault
F51	Fault record 3 Voltage at fault	-V	-	
F52	Fault record 3 Current at fault	-A	-	
F53	Fault record 3 Temperature at fault	-°C	-	
F54	Cumulative number of operations	0-65535	-	
F55	Cumulative operating time	0-65535	-	The total operating time format is: F55 (hour/h); F56 (minute/m); F57 (second/S)
F56	Cumulative operating time	0-60	-	
F57	Cumulative operating time	0-60	-	
F58	Overload protection level	0~4	1	0 = class2 1 = class10a 2 = class10 3 = class20 4 = class30
	Inverse time protection curve for release protection level of motor under hot state based on IEC60947-4-2 (acting on operation); Inverse time protection curve for release protection level of motor under cold state based on IEC60947-4-2 (acting on initial startup); When the motor's operation needs to meet the overload level of class20 and above, i.e. heavy load application, the power selection of the soft starter shall be fully amplified; otherwise, the soft start module may be overheated or overloaded.			
F59-F64	(Function reserved)			
F65	Software version No.	-	-	Refer to the statement on the attached page of the revised notes or marking of the title page for the software version No. applicable to this manual
F66	User password	0-65535	-	
F67	Manufacturer password	-	-	For internal use only
F68	Integrator password	-	-	The integrator password is used to set the parameters of functions F69 to F73, and set limits on product run time, number of runs, etc., so as to facilitate the integrator to carry out product trials, test runs, etc.
F69	Running count lock	-	-	Setting of number of runs, the product will be locked and the alarm Err17 will be generated when the set run is reached
F70-F73	For integrator	-	-	
F74-F99	Manufacturer's parameters	-	-	For internal use only

Protection Release Curve

Motor thermal protection tripping time curve based on IEC60947-4-2 is as follows:

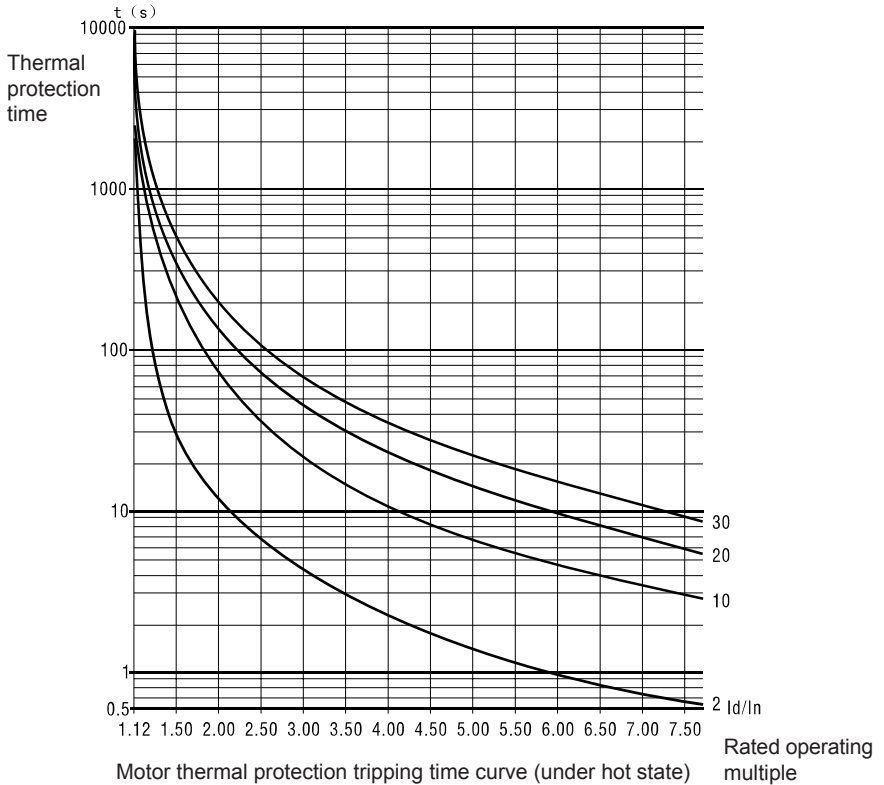

Referring to IEC thermal protection tripping curve standard, the motor power marked in model rule description ③ is the reference power for Class 10 application. When the load is heavy and the release level is required to be higher than 10, the selection of soft starter shall be amplified.

The above figure is only for reference of model selection and protection setting, and for reference of non-protection action, refer to the function list for specific overload protection action time.

The above figure shows the reference curve under hot state, and the time of curve under cold state is shorter. Due to the limited length of this manual, the detailed standard description will not be provided. If necessary, please search and check the relevant standard documents by yourself.

Communication

Communication RS485

MODBUS communication, 9600.n.8.1, byte transfer, hexadecimal representation, Q&A transfer. There is a communication terminal resistance jumper J1 inside the mainboard of the machine.

I. Data and Condition Monitoring

Host sends: (function code=03, reading all data), reading up to 10 registers

Slave address	Function code	High order register address	Low order register address	High order data quantity	Low order data quantity	CRC
01	03	10	00~2C	00	X	CRC

Return of equipment:

Slave address	Function code	High order data quantity	Low order data quantity	Data 0	Data 0	Data X	Data X	CRC
01	03	00	2~2*X	0H	0L	xH	xL	CRC

Register address table:

Register address	Register Name
1000H	Phase A current
1001H	Phase B current
1002H	Phase C current
1003H	Bus voltage
1004H	Temperature
1005H	Fault code
1006H	System state
1007H	Input and output state of terminal
1008H	Analog output (AO)
1009H	-

System state: 1006H

State code	Content
0001	Start state
0002	Run state
0003	Soft start state
0004	Stop state
0005	Fault state

Terminal state: 1007 H (No Input/Output, 1: With Input/Output)

Bit No.	BIT7	BIT6	BIT5	BIT4	BIT3	BIT2	BIT1	BIT0
Content	NC	NC	BYPASS	PROG	FAULT	E-STOP	S-STOP	RUN
State (initial)	0	0	0	0	0	0	0	0

II. Parameter Query (EEPROM)

Host sends: (function code=03, reading EEPROM data), reading up to 10 registers

Slave address	Function code	High order register address	Low order register address	High order data quantity	Low order data quantity	CRC
01	03	00	00~FF	00	1~10	CRC

Return of equipment:

Slave address	Function code	High order data quantity	Low order data quantity	Data 1	Data 1	Data X	Data X	CRC
01	03	00	1~12	1H	1L	xH	xL	CRC

III. Parameter Setting (EEPROM)

Host sends: (function code 06, reading EEPROM data)

Slave address	Function code	High order register address	Low order register address	High order data quantity	Low order data quantity	CRC
01	06	00	00~FF			CRC

Return of equipment:

Slave address	Function code	High order register address	Low order register address	High order data quantity	Low order data quantity	CRC
01	06	00	00~FF			CRC

IV. Control Command

Host sends: (function code 06)

Slave address	Function code	High order register address	Low order register address	High order data quantity	Low order data quantity	CRC
01	06	20	00	00	00	CRC

Return of equipment:

Slave address	Function code	High order register address	Low order register address	High order data quantity	Low order data quantity	CRC
01	06	20	00	00	00	CRC

Control command input to soft start

Address	Command data	Function
2000H	0001	Start
	0002	Free stop
	0003	Soft stop
	0004	Fault reset

Fault Diagnosis and Countermeasures

List of Protection Actions

When an abnormality occurs in the soft starter, the protection function operates and the circuit trips immediately. The LCD displays the name of the alarm and the relevant content please refer to the description in the table below.

Display code	Name of fault	Fault diagnosis	Countermeasures
Err01	Output phase loss	Because the phase loss detection is affected by many related factors, the input and output circuits shall be comprehensively inspected during inspection.	1, 2. Check and eliminate the problems existing in the power line, including but not limited to abnormal power frequency (not 50/60HZ), phase loss or high frequency harmonic in the line. Check the output line and the isolation equipment (contactor, fuse, circuit breaker, etc.) between the main circuit
Err02	Input phase loss	1. Abnormality in three-phase input power supply 2. Abnormality in the line from the soft start output to the motor 3. Thyristor fault of soft starter 4. Motor fault 5. The setting of starting current limiting is too low	3. Seeking technical support 4. Check the motor 5. Adjust the current limiting multiple (F04) to appropriate range
Err03	Start timeout	1. Mechanical abnormality at load end. 2. The setting value of starting time is too low. 3. Specification of soft starter does not match the load characteristics or power. 4. Current limiting multiple is set too low.	1. Eliminate possible problems such as blockage, abrasion, mechanical clearance and lubrication 2. Increase start time (F35) 3. Adjust the starting voltage (F03) or use the current limiting mode. When the parameter setting adjustment cannot meet the performance requirements, the soft starter with higher power level shall be selected 4. Adjust the current limiting (F04) setting and it is recommended not to exceed 400% of the motor rating
Err04	Radiator overheating	1. Starting too frequently 2. Specification of soft starter does not match the load characteristics or power 3. Excessively high ambient temperature 4. The air duct is blocked or the fan is damaged 5. The modular temperature sensor is damaged	1. Reduce the start and stop frequency to a reasonable range 2. Select soft starter with higher power level 3. Reduce ambient temperature or consider capacity-reductive selection (refer to description of electrical parameter) 4. Clean the air duct or replace the faulty fan 5. Replace the temperature sensor

Fault Diagnosis and Countermeasures

Display code	Name of fault	Fault diagnosis	Countermeasures
Err05	Start overcurrent	<ol style="list-style-type: none"> 1. Overload or motor locked-rotor 2. Specification of soft starter is relatively small 3. Internal short circuit of soft starter 4. Bypass contactor adhesion 5. Output short circuit of soft starter 	<ol style="list-style-type: none"> 1. Reduce load and check motor and mechanical condition 2. Select the soft starter with higher power level and appropriately increase the overload protection level of F58 3. Check the thyristor 4. Check bypass contactor 5. Eliminate output short circuit to ground or check motor insulation
Err06	Running overload	<ol style="list-style-type: none"> 1. Overload or motor locked-rotor 2. Specification of soft starter is relatively small 3. The overload threshold is set too low 	<ol style="list-style-type: none"> 1. Reduce load and check motor and mechanical condition 2. Select soft starter with higher power level 3. Set the overload threshold to the proper range
Err07	Grid overvoltage	<ol style="list-style-type: none"> 1. The input grid voltage is excessively high 	<ol style="list-style-type: none"> 1. Regulate the voltage to the range required by the specification
Err08	Grid undervoltage	<ol style="list-style-type: none"> 1. The input grid voltage is excessively low 2. Instantaneous power outage 	<ol style="list-style-type: none"> 1. Regulate the voltage to the range required by the specification 2. Reset fault
Err09	Underload	<ol style="list-style-type: none"> 1. The operating current is lower than the set value 2. Mechanical abnormality at load end 3. Abnormality in Current detection 4. Abnormality in operation output connection 	<ol style="list-style-type: none"> 1. Adjust relevant parameters of underload protection (F14/F15/F16) 2. There is mechanical fault of the load, such as off-loading or under-loading due to loss of pressure in the pipe, reversal of rotation, belt loosening, mechanical clearances, etc 3. Seek technical support 4. Check the connection cable from soft start to motor load
Err10	Three-phase unbalance	<ol style="list-style-type: none"> 1. Abnormality in grid voltage 2. Abnormality in motor or the connection cable of motor 3. The allowable range of three-phase unbalance is too small 4. Hardware abnormality in detection circuit 	<ol style="list-style-type: none"> 1. Check the voltage of main circuit 2. Check motor and motor cable 3. Properly adjust the allowable range of three-phase unbalance (code F12) and three-phase unbalance protection delay (code F13) 4. Seek technical support

Fault Diagnosis and Countermeasures

Display code	Name of fault	Fault diagnosis	Countermeasures
Err11	Fault in memory	1. Abnormality in reading and writing of software setting 2. Fault in register hardware	1. Power on again after power outage. If the fault is not eliminated, restore the factory value (code F39) 2. Seek technical support
Err12	Fault in current sampling	1. Hardware fault	1. Seek technical support
Err13	Fault in temperature sampling	1. Hardware fault	1. Seek technical support
Err14	Open circuit of instantaneous stop terminal	1. The emergency stop terminal is not short-circuited	1. Short-circuit the external instantaneous stop terminal ⑦ with the common terminal ⑩, or connect it to the normally closed contact of other protective devices.
Err15	Open circuit of stop terminal	1. The stop terminal is not closed when not normally closed	1. Check the secondary circuit
Err16	External fault	1. There is an external input fault signal from DI1 to DI3 terminals	1. Check the corresponding external fault signal input point and remove the external fault
Err17	Number of runs reached	1. Running count lock is set	1. Contact the integrator for modification
Err18	Inverse time overload protection	1. Operation overload 2. Improper setting of F58 overload protection level	1. Reduce load 2. Properly increase the protection level

Remarks: Some fault phenomena are interrelated, for example, the report Err04 of soft starter overheating may be related to the starting overcurrent or load short circuit. Therefore, when diagnosing the fault, comprehensive consideration shall be given to accurately determine the fault point.

Fault Diagnosis and Countermeasures

Other Common Faults and Solutions

No.	Fault phenomenon	Possible reasons	Solutions
1	The motor does not rotate or rotates slowly after starting, and the current is large	1. The starting torque is small 2. Overload, locked-rotor or being locked	1. Properly adjust the starting voltage and starting time, adjust the starting current in current limiting mode or use other starting modes 2. Check the load
2	Abnormal sound when the motor is stopped	Incorrect setting of soft stop time	Adjust the soft stop setting (multiple adjustments may be necessary to obtain the desired result)
3	The load is the compressor and the starting current is large	1. The starting time is set too long	1. Some compressors are equipped with air valve devices. Excessive slow starting may cause the air valve unable to be opened, which shall be properly adjusted according to the actual situation
4	Sudden stop during operation with no alarm code displayed	1. Abnormality in external input terminal	1. Check whether the emergency stop signal terminal, external stop terminal and connected button wiring are abnormal. If there is an external protector, please check whether it acts.
5	Motor stops by itself after normal start	1. Abnormal operation of bypass contactor	1. Check the bypass output wiring or contactor
6	Output terminal is electrified when soft start is not started	The induced voltage at the output end of the soft starter is normal when it is unloaded, which will not affect the use. The induced voltage is generated by leakage of SCR (SCR, GTR, IGBT and other solid-state semiconductor devices all have different degrees of leakage) and the AC path of dv/dt resistance-capacitive filter circuit. Use a voltmeter to measure zero, which is about 100~220V. The induced voltage load capacity is very small and will disappear after the output is connected to the load.	
7	Display deviation of low ambient temperature	The effective temperature monitoring range of L-series soft start is 0~110°C. When the detection temperature is lower than 0°C, 0°C will be displayed. The factory default temperature protection action threshold is of 85°C.	

Warranty and After-sales Service

Thank you very much for purchasing the soft starter produced by our company. This product is manufactured under the perfect quality management system. For your convenience, we hereby make the following instructions for the warranty period and after-sales service commitment:

1. Scope of Warranty

The warranty period of the product is 12 months after purchase and 24 months from the manufacturing date recorded on the nameplate, and exceeding any one of the two is considered out of warranty period. However, if the fault is caused by the following reasons, it shall be repaired with compensation even within the warranty period.

- 1) Due to incorrect use, self-modification and improper maintenance.
- 2) Use in excess of standard specifications.
- 3) Falling and damage during transportation after purchase.
- 4) Earthquake, fire, windstorm, lightning, abnormal voltage, other force majeure disasters and secondary disasters, etc.

2. After-sales Service

- 1) In case of poor use condition, please check first. Please read and check again against the operating instructions.
- 2) In the event of a fault, please contact the distributor or the "After-sales Service Counter and Office of the Company" listed in the operation manual.
- 3) Repairs within warranty period: repairs will be free of charge in case of faults caused by manufacturing problems of the Company. However, all contents in the "Warranty Form for Soft Starter" must be filled in correctly and in detail. Otherwise, repairs will be carried out at a cost.
- 4) Beyond the warranty period: if the function can be maintained after repair, the product will be repaired at the customer's request with charge.

3. Service Commitment

- 1) Provide technical support for customers in the use and operation of soft starters: At the beginning of use, the Company will train relevant technical personnel and guide customers in the use of the soft starter free of charge.
- (2) The Company will respond to customers' requests for technical services and maintenance services by telephone 24 hours a day.

Repair Record Card

Soft Start Warranty

Name of user	Person(s) in charge:	Telephone:
User address	Fax:	
Product model	KW	Ex-factory serial No.:
Name of agent	Purchase date:	MM DD YY
Agent Address	Date of fault:	MM DD YY

Fault condition

Purpose:	Motor:	KW	Pole
Model No.:			
Fault occurrence:	In continuous operation:	In acceleration:	
In deceleration:	When power on:	Other:	
Display of fault occurrence time:		Alarm display:	
With / without the keyboard displays:		With / without output voltage:	
Operation after reset:	Possible Terminal	Impossible Power supply	Reset method Other
Keyboard panel			
Use control terminal:	01, 02	03, 04	05, 06
	07	08	09
	10	11, 12	Other
Working hours:	Frequency at fault occurrence		/ Installation site
Power outage: Yes/No	Abnormality in surrounding machine		
Past fault: Yes (times)/No			

During warranty, this page can be torn off and placed in the equipment package, and relevant information shall be filled in. Make sure that this page cannot be lost, and the Company will not be responsible for any loss caused thereby.

This manual is of great significance to the use and maintenance of the product.
Please submit this manual to the end user together with the product and keep it properly.

Technical parameters are subject to change without notice.
The Company reserves the right of final interpretation of the above information.
All rights reserved by the Company. Reprinting is strictly prohibited.
The inner picture is for reference only.



Apr. 21st, 2023